

**PARTS LIST:**

1	Driver/Left side Running Board	16	8mm x 24mm x 2mm Flat Washers
1	Passenger/Right side Running Board	16	6mm x 20mm T-Bolts
8	Mounting Brackets	16	6mm x 22mm x 2mm Flat Washers
16	8-1.25mm x 30mm Hex Bolts	16	6mm Lock Washers
16	8mm Lock Washers	16	6mm Hex Nuts

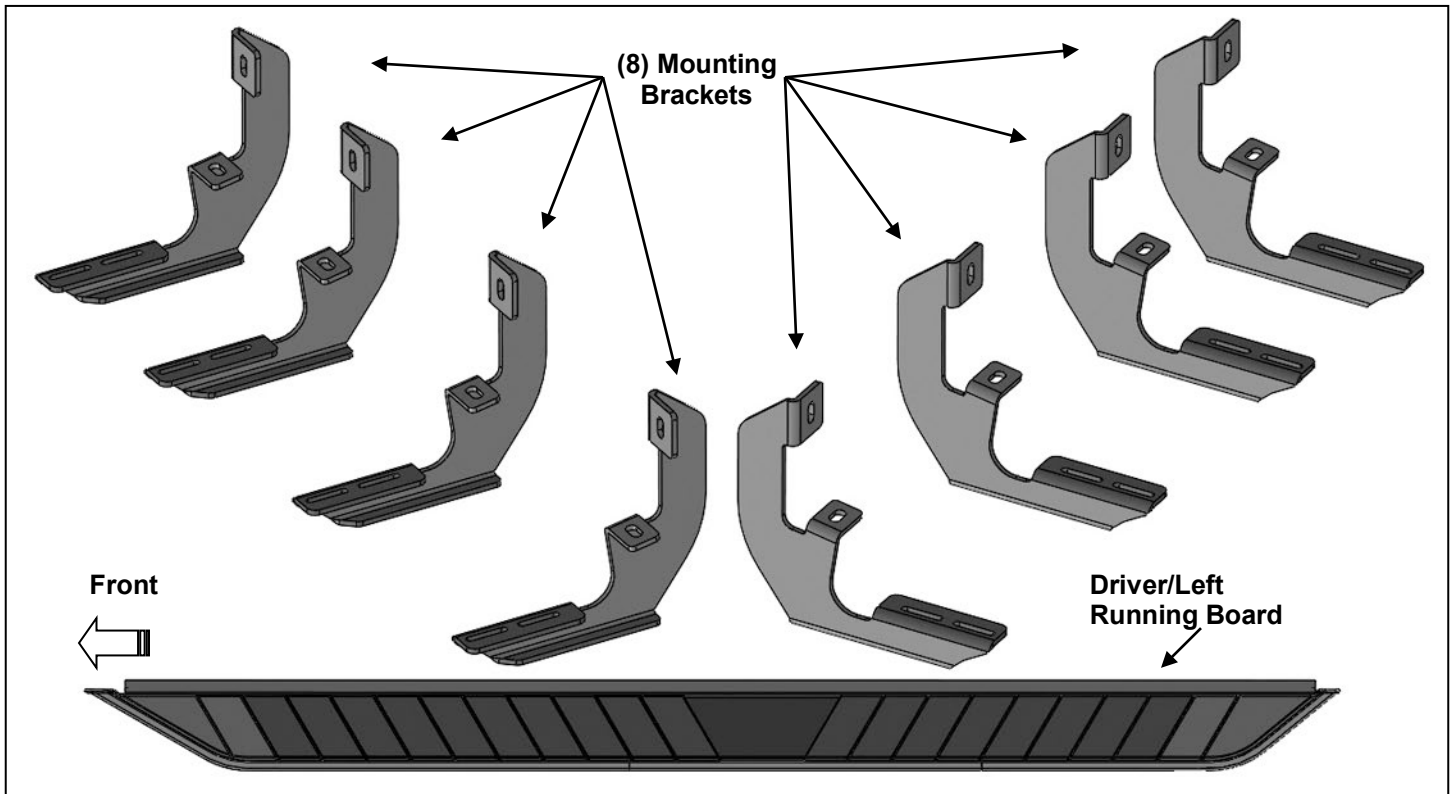

**PROCEDURE:**

**REMOVE CONTENTS FROM BOX. VERIFY ALL PARTS ARE PRESENT. READ INSTRUCTIONS CAREFULLY BEFORE STARTING INSTALLATION. ASSISTANCE IS RECOMMENDED.**

1. Start the installation under the Driver/Left side of the vehicle. Locate the 6 plugs along the bottom edge of the body. Mounting Brackets will bolt to the 1st, 3rd, 4th and 6th threaded mounting holes, **(Figures 1—6)**. Remove the plastic plugs from each mounting location. Directly above each threaded insert is a top mounting location on the side of the body panel. Hold a Bracket up in place to help determine the mounting holes to use along the body. **NOTE:** Thread an 8mm Hex Bolt into the threaded inserts to clear paint as required.
2. Select (1) Mounting Bracket. Starting at the front of the Driver/Left side, bolt the Mounting Bracket to the factory threaded holes with (2) 8mm Hex Bolts, (2) 8mm Lock Washers and (2) 8mm Flat Washers, **(Figure 7)**. Do not tighten hardware at this time.
3. Repeat **Steps 1 & 2** to install (3) Mounting Brackets on the remaining Driver/Left side mounting locations along the body panel.
4. Select the Driver/Left Side Running Board. Use the illustration above to help determine the correct Running Board. Place the Running Board on top of the Brackets. Locate the channel openings in the bottom of the Running Board. Select (8) 6mm T-Bolts, **(Figure 8)**. Insert the T-Bolts into the channels in the bottom of the Running Board, slide T-Bolts through channel close to brackets, **(Figure 9)**. Lift the Running Board up and guide the studs through the Brackets.
5. Attach the Running Board to the Brackets with (8) 6mm Flat Washers, (8) 6mm Lock Washers and (8) 6mm Hex Nuts, **(Figure 10)**.

6. Level and adjust the Running Board and fully tighten all hardware.
7. Repeat **Steps 1—6** to install the Passenger/Right Side Running Board.
8. Do periodic inspections to the installation to make sure that all hardware is secure and tight.

**To protect your investment**, Do not use any type of polish or wax that may contain abrasives that could damage the finish. Mild soap may be used also to clean Running Board.

### Driver/Left side Installation Pictured

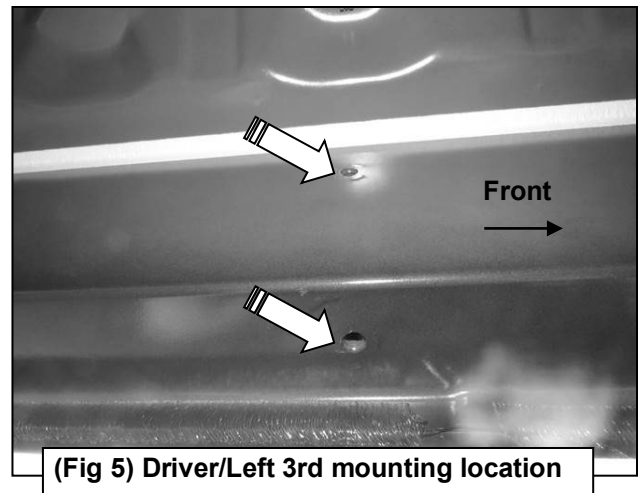
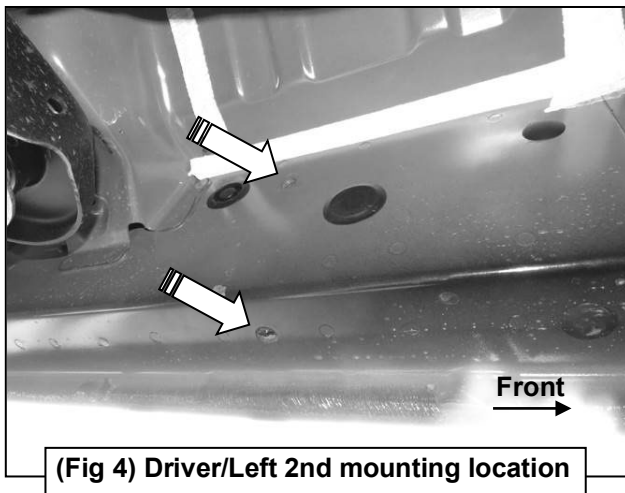
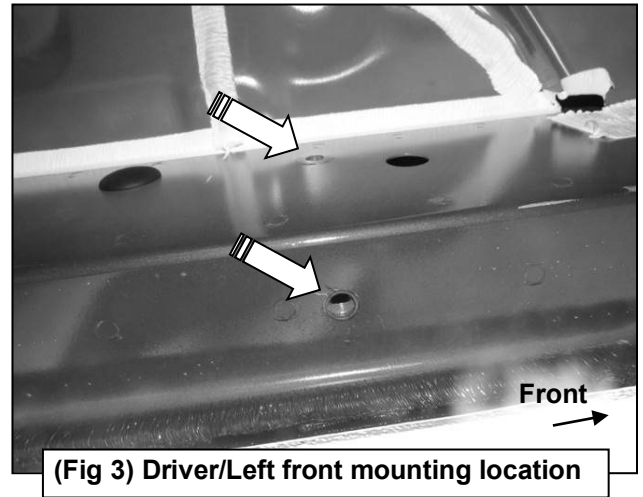
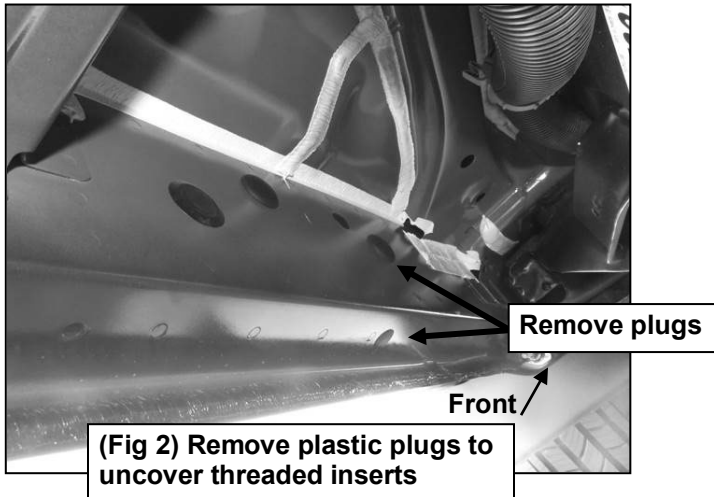
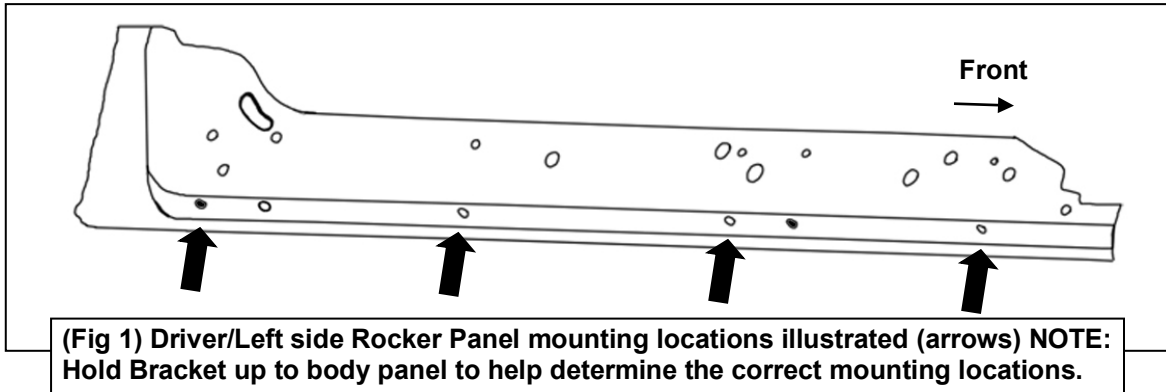

### Driver/Left side Installation Pictured

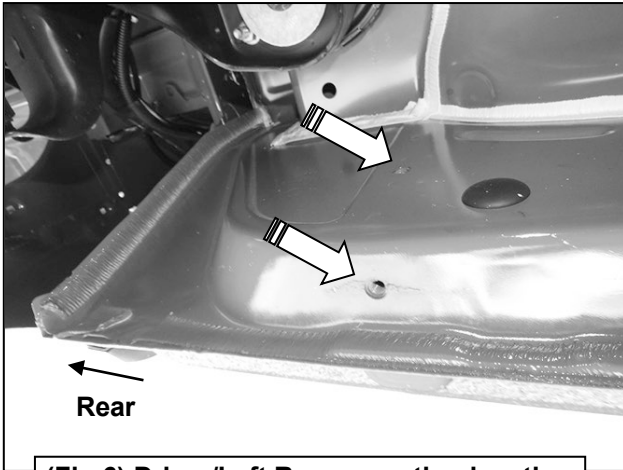

(Fig 6) Driver/Left Rear mounting location

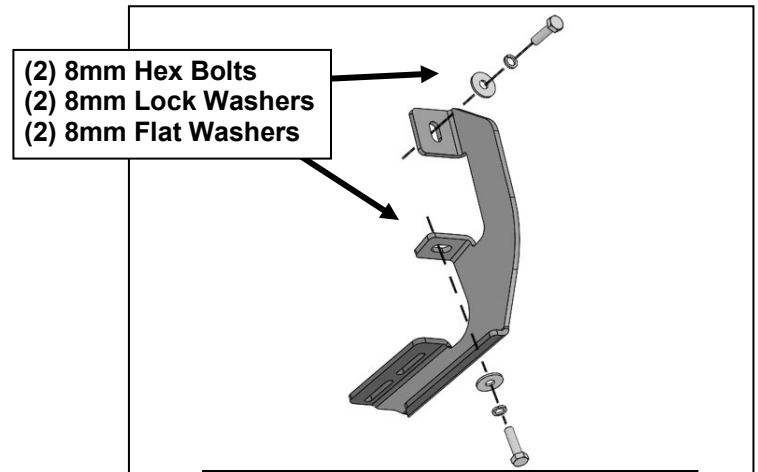

(Fig 7) Mounting Bracket illustration

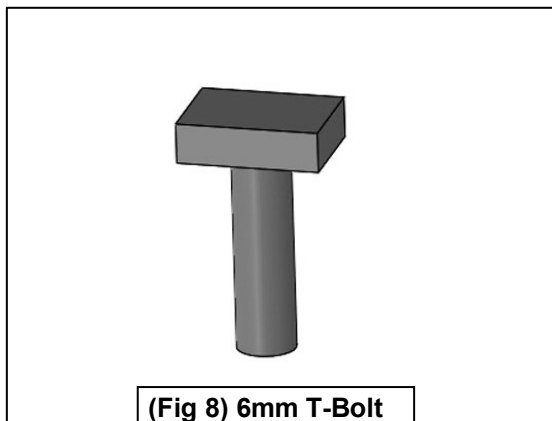

(Fig 8) 6mm T-Bolt

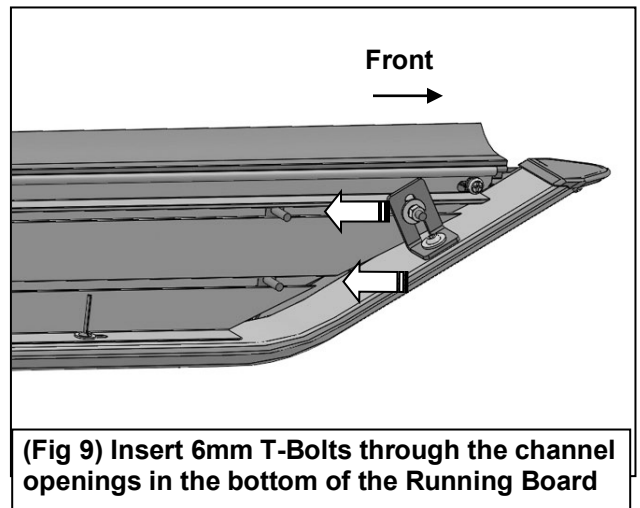

(Fig 9) Insert 6mm T-Bolts through the channel openings in the bottom of the Running Board

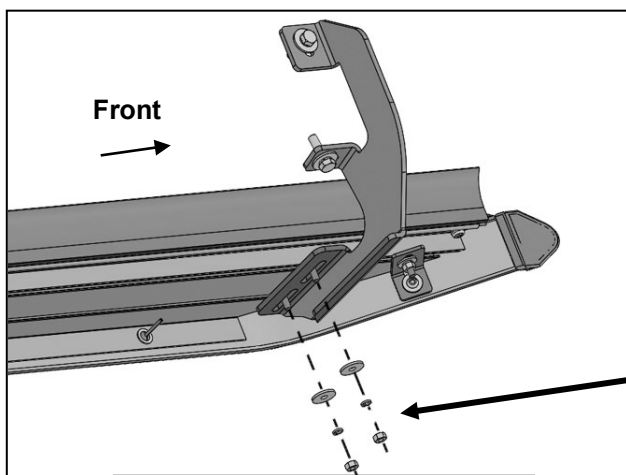

(Fig 10) Running Board attached to Bracket illustrated