

INSTALLATION INSTRUCTIONS

PART#EWRPCR09

HD2 SIDE STEP FOR DODGE RAM CREW CAB 09-18

Before Installation

- Please read the instruction completely for easy installation, which will also help you to avoid scratches or other potential damages to your appealing car.
- The figures here are for reference only and may have differences with the actual product you received, however they share the same assembly way.





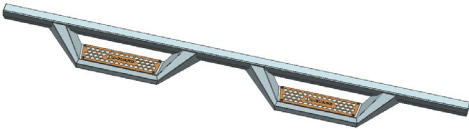
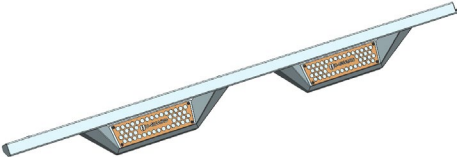
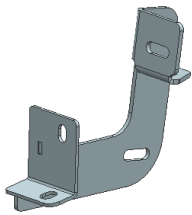
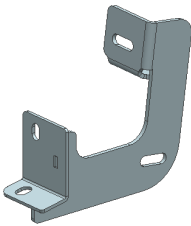
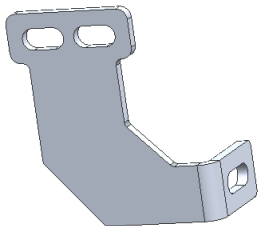
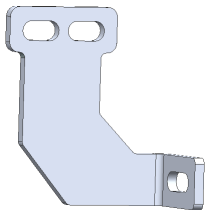

Care and Cleaning

- Mild soap may be used also to clean the Product.
- Please periodically check and retighten all the hardware and clean the investment for a refresh look.

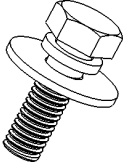
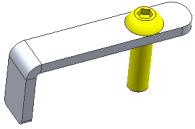
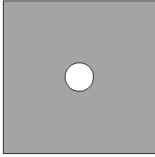
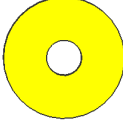
Parts list

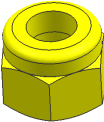
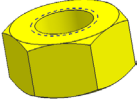
NO.	QTY	PIC	NO.	QTY	PIC
①	1	 <p style="text-align: center;">Side step (L)</p>	②	1	 <p style="text-align: center;">Side step (R)</p>
③	3	 <p style="text-align: center;">Bracket (L)</p>	④	3	 <p style="text-align: center;">Bracket (R)</p>
⑤	3	 <p style="text-align: center;">Mounting bracket (L)</p>	⑥	3	 <p style="text-align: center;">Mounting bracket (R)</p>

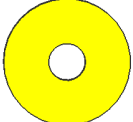
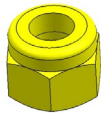
INSTALLATION INSTRUCTIONS

⑦	12	 Hex head bolt, spring washer and large washer assembly M8_25	⑧	6	 T Bolt (M8x30)
⑨	6	 PVC Plastic Block $\phi 8$	⑩	18	 Large washer D8(8x24x2mm)
⑪	6	 Spring washer D8	⑫	6	 Nylon lock nut M8
⑬	6	 Hex nut M8	⑭	12	 Hex head bolt M8_30
⑮	24	 Large washer D6(6x22x2mm)	⑯	12	 Nylon lock nut M6
⑰	12	 Hex head bolt M6_25			

Installation Steps

To protect your investment, Do not use any type of polish or wax that may contain abrasives that could damage the finish. Mild soap may be used to clean the Running Boards.

Driver/Left Side Installation Pictured

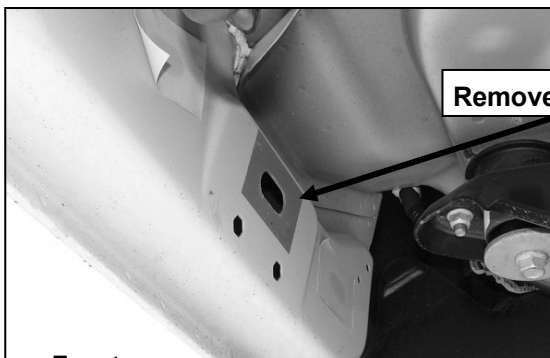

Front

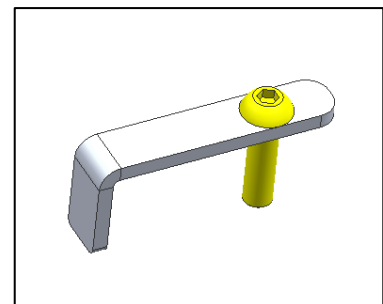

(Fig 1) 2009-mid 2015 driver front mounting location (No factory holes in pinch weld 2009-2012 models)



(Fig 2) 8mm Bolt-Nut Plate,

INSTALLATION INSTRUCTIONS

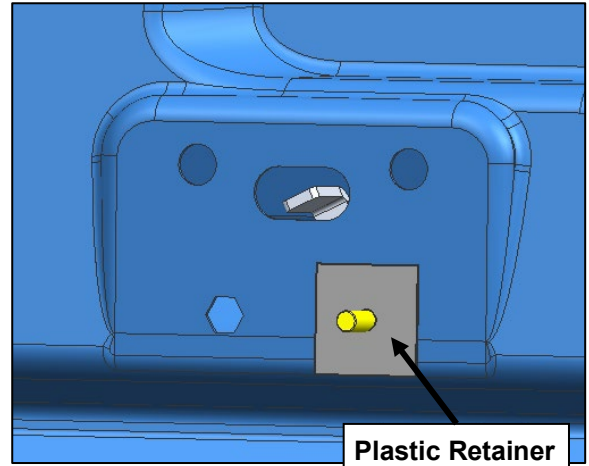
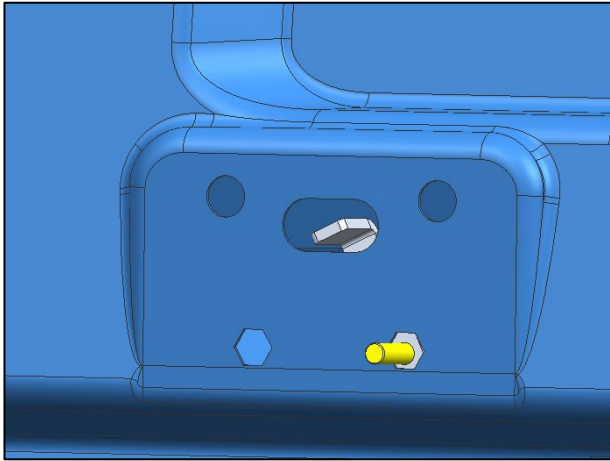
Driver/Left Side Installation Pictured



(Fig 4) Use the loose Hex Bolt as a handle. Insert the Bolt Plate into the oval hole and feed the threaded end out either factory hex shaped hole. (Fig 5)

(Fig 5) Thread Plastic Retainer onto Bolt Plate to hold Bolt Plate in position.

8mm Flat Washer
8mm Lock Washer
8mm Hex Nut
Plastic Retainer

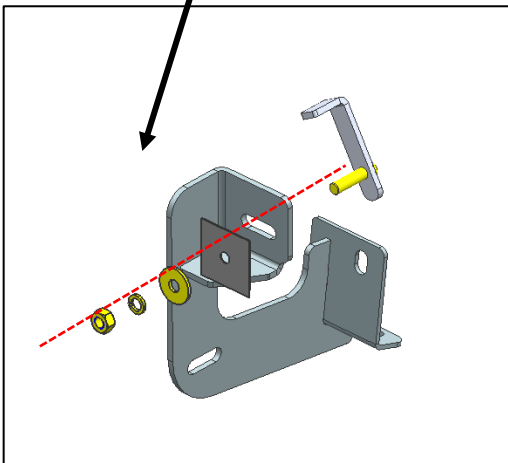

(Fig 6) Remove 8mm Hex Bolt. Rotate Bolt Plate to line up with remaining factory hex shaped hole

INSTALLATION INSTRUCTIONS

Driver/Left Side Installation Pictured

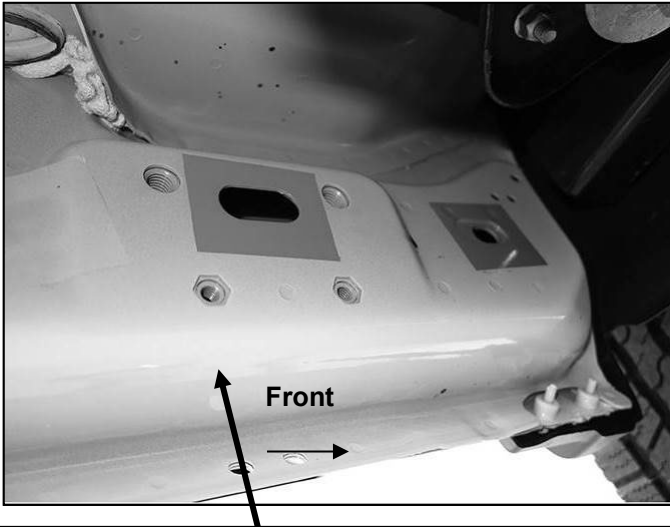

(Fig 8) Driver/left side front mid 2015-on (example of models with factory installed threaded inserts)

IMPORTANT: 2009-2012 models without holes in pinch weld will require drilling 1/4" holes through pinch weld to attach the bracket. Do complete installation of Running Boards first, level Running Board before drilling holes for bracket.

- (1) 8mm Hex Bolts
- (1) 8mm Lock Washers
- (1) 8mm Flat Washers

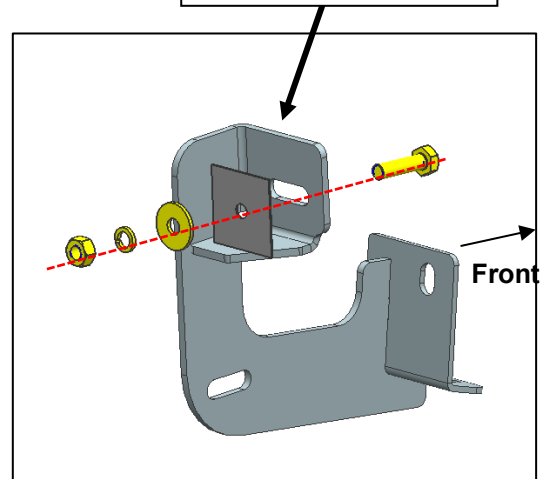

(Fig 9) Driver/left side front models with factory installed threaded inserts. Bolt Plate not required

- (2) 6mm Hex Bolts
- (4) 6mm Flat Washers
- (2) 6mm Nylon Lock Nuts

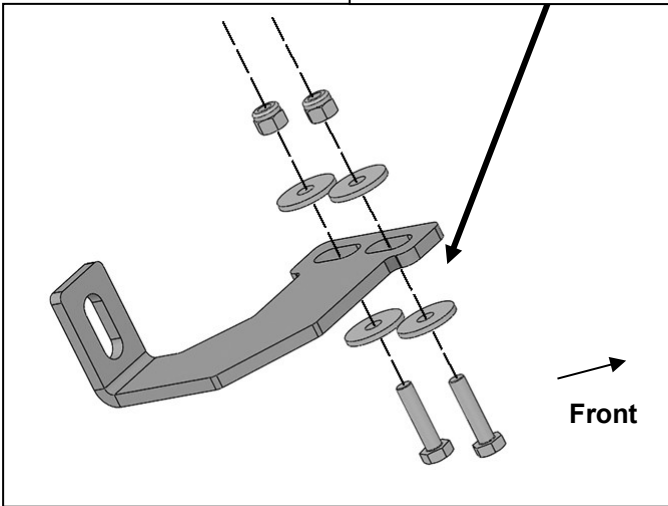

(Fig 10) Attach the Support Bracket to back of pinch weld (models with factory holes in pinch weld only)

- 8mm Hex Bolt
- (2) 8mm Flat Washers
- 8mm Nylon Lock Nut

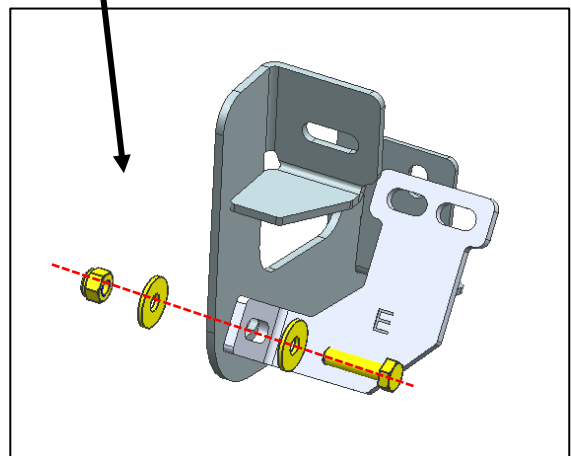

(Fig 11) Attach the Support Bracket to the Mounting Bracket

INSTALLATION INSTRUCTIONS

Driver/Left Side Installation Pictured

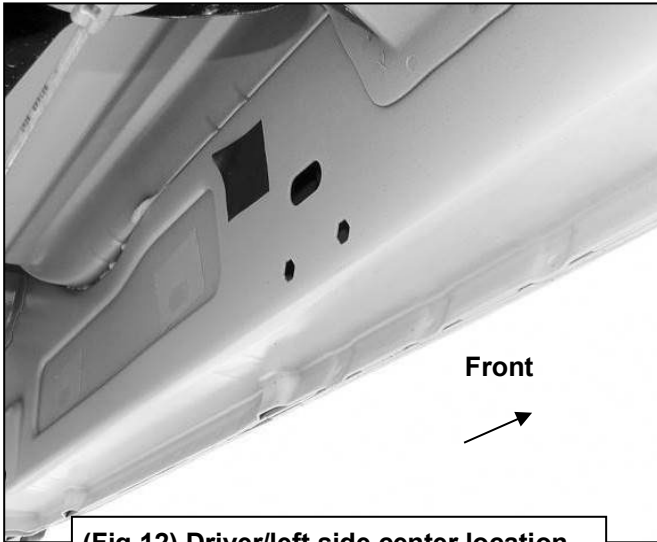

(Fig 12) Driver/left side center location

IMPORTANT: 2009-2012 models without holes in pinch weld will require drilling 1/4" holes through pinch weld to attach the bracket. Do complete installation of Running Boards first, level Running Board before drilling holes for bracket.

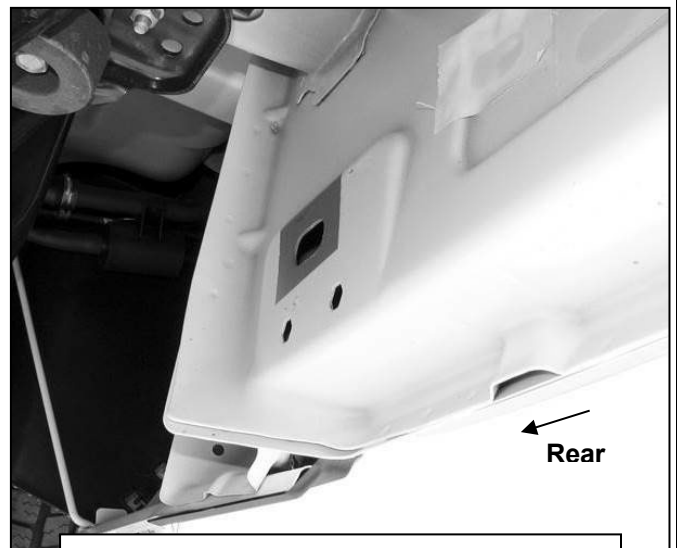

(Fig 13) Driver/left rear mounting location

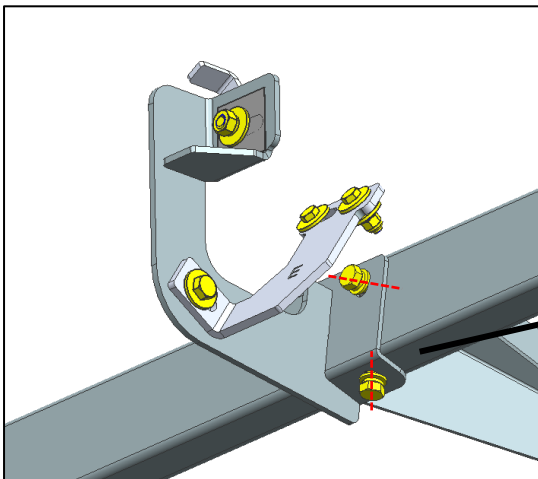

(2) 8mm Combo Bolts

(Fig 14) Attach the Driver/Left Running Board to the (3) Mounting Brackets

NOTE

Any damages and losses caused by improper installation and application, goes beyond our quality warranty.